

# Sankyo

All for dreams

## Programmable magnetic encoder EA Series Product Specification (EA05R03) Ver 1.0.0 ASR-NP-20938-01

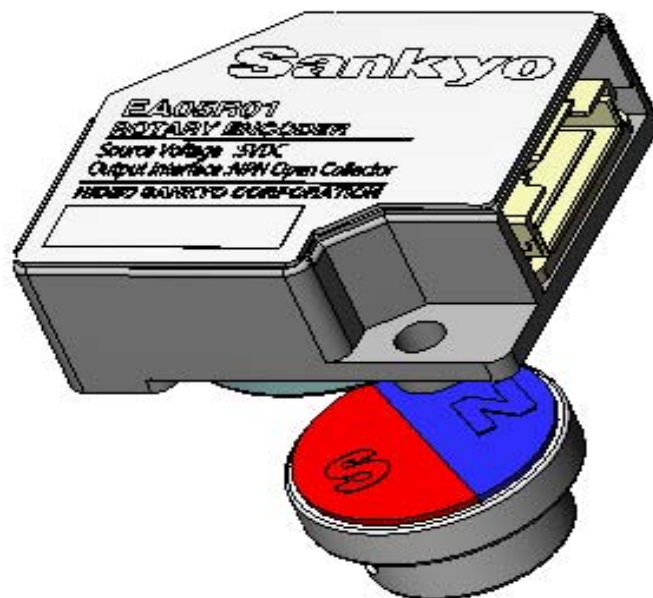

**NIDEC SANKYO CORPORATION**

# (REVISION LIST)

ASR-NP-17647-01

sym	Change content		(No. of ECR/ECN)
-	New execution	Rev 1.00	

# Contents of Products Specification

- 1 Scope of application
- 2 Outline of product
  - 2-1 Outline
  - 2-2 Configuration
- 3 Function/Specifications
  - 3-1 Absolute maximum rating
  - 3-2 Mechanical specifications
  - 3-3 Electrical specifications
  - 3-4 Factory default setting
  - 3-5 Interface specifications
    - 3-5-1 Installation
    - 3-5-2 Connector pin assignment
    - 3-5-3 Input/output circuit
    - 3-5-4 Error handling
    - 3-5-5 A/B ch specifications
    - 3-5-6 Serial communication specifications
  - 3-6 Resolution list
- 4 Reliability test
- 5 Cautions in handling
- 6 Appearance reference diagram

## Attached materials

An instruction manual will be attached at the customer's request.

## 1 Scope of application

This specification applies to magnetic type rotary encoder **EA05R03**  
(Line drive output type) manufactured by NIDEC SANKYO CORPORATION

## 2 Outline of product

### 2-1 Outline

Magnetic type single-turn absolute encoder  
(operable as incremental encoder by parameter setting)  
Magnetic resistance element (MR element) adopted in sensor part  
Output function by OUT terminal (A/Bch:4CH, serial communication:2CH are settable)  
Various functions can be changed by setting parameters from a personal computer via this product and parameter setting tool (using UART communication in 5V TTL level).  
Change of output mode (switching of "A/Bch," "serial communication")  
Change of resolution (settable to resolutions listed in 3-6 Resolution list (Page 9))  
Change of origin position  
Output position (angle) of OUT terminal settable  
A/Bch direction: A-ch advance, B-ch advance can be switched  
A/B ch mode: Change of incremental output, absolute output (see 3-5-5 A/B ch specifications)  
Serial communication mode: Up-count and down-count can be changed  
Serial communication mode: Change of communication format  
Serial communication mode: Upper-level bit or lower-level bit of transmission bit can be switched.

### 2-2 Configuration

Shipment

NO.	Part name	Drawing No.	Quantity	MFR	Remarks
1	Encoder	-	1	-	EA05R01
2	Magnet	-	1	-	Shaft diameter 4 or 5 can be selected
3	Screw	-	2	-	JIS B 1177 Flat-Tipped M2×3 45H

Parts prepared by customer

NO.	Part name	Drawing No.	Quantity	MFR	Remarks
4	Cable assembly	-	1set	-	
5	Motor	-	1	-	
6	Encoder mounting screw	-	2	-	M2 × 6 washer, with spring washer
7	Base mounting screw	-	2	-	
8	Encoder mounting base	-	1	-	

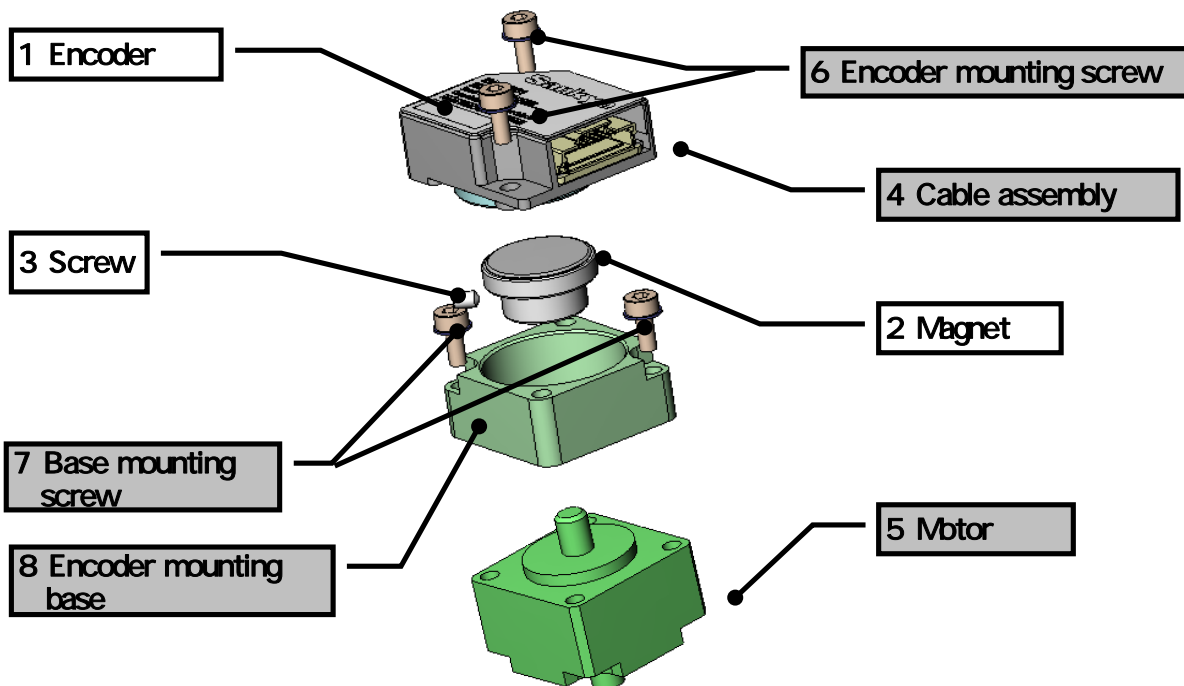

Fig. 1 Product configuration diagram

### 3 Function/specification

#### 3-1 Absolute maximum rating

Specification item	Content	
Rated power voltage	VCC	DC -0.3V +5.5 V
Input voltage	Vin	0 VCC V
Operating ambient temperature		-10 +85
Operating ambient humidity		20 80%RH No condensation
Storage temperature		-10 +90

#### 3-2 Mechanical specifications

Function/Specifications	Content
External disturbance magnetic field	Within ±2mT
Mass	Sensor part
	Magnet part
Magnet inertia moment	0.85 g cm <sup>2</sup>
Outside dimensions	See OUTSIDE DRAWING T09A665A01

#### 3-3 Electrical specifications

Specification item	Output mode	A/Bch output	Serial communication output
Recommended power voltage		DC 5V ± 10%	
Consumption current		20mA or less	
Output type			
Input voltage	Connector pin assignment	See 3-5-3	
	Low level range		
Output type		A/Bch	Binary Serial output
Maximum response frequency		60 KHz	-
Allowable maximum rotating speed		Note 1	Note 2
Maximum resolution		8192 [division/rev] ( 2048 [pulse/rev] )	32768 [division/rev]

Note 1 Allowable maximum rotating speed in A/Bch mode (Electrical)

Maximum response rotating speed is specified from resolution [division/rev] (after multiplying by four) and maximum response frequency [Hz].

$$\text{Electrical maximum response rotating speed [rev/min]} = \frac{\text{Maximum response frequency (60 [KHz])}}{\text{resolution}} \times 60 \times 4$$

Note2 Allowable maximum rotating speed in serial communication mode (Electrical)

Maximum response rotating speed is specified from request frequency [sec].

$$\text{Electrical maximum response rotating speed [rev/min]} = \frac{30}{\text{request frequency}}$$

3-4 Factory default setting

Parameter setting item	Setting content
Output mode	A/Bch
Resolution	1024 [division/rev] (256 [pulse/rev])
A/Bch direction	A-ch advance (in CW rotation)
OUT terminal setting	Zch (1pulse/rev)
Rotating direction designation	CW direction is clockwise as viewed from encoder ring side.
A/Bch mode	Absolute
Error signal	RS422A line driver to be Hi impedance

3-5 Interface specifications

3-5-1 Installation

Checking dimensions of installation shaft

Check that dimensions of the installation “shaft” satisfy the specifications shown below.

Note) If dimensions exceed the allowable range, not only will product performance be inefficiently utilized, but damage may also result to the product.

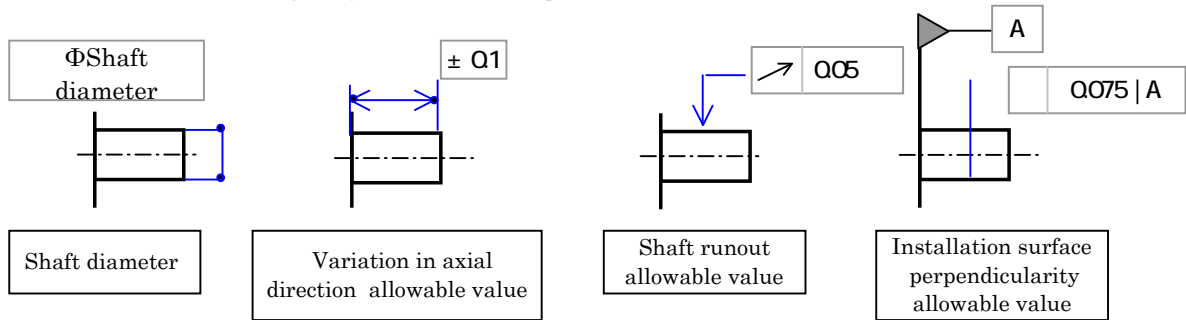

Fig. 2 Dimensions of installation shaft

Outline description of installation

See OUTSIDE DRAWING T09A665A01 for detailed dimensions of fitting part.

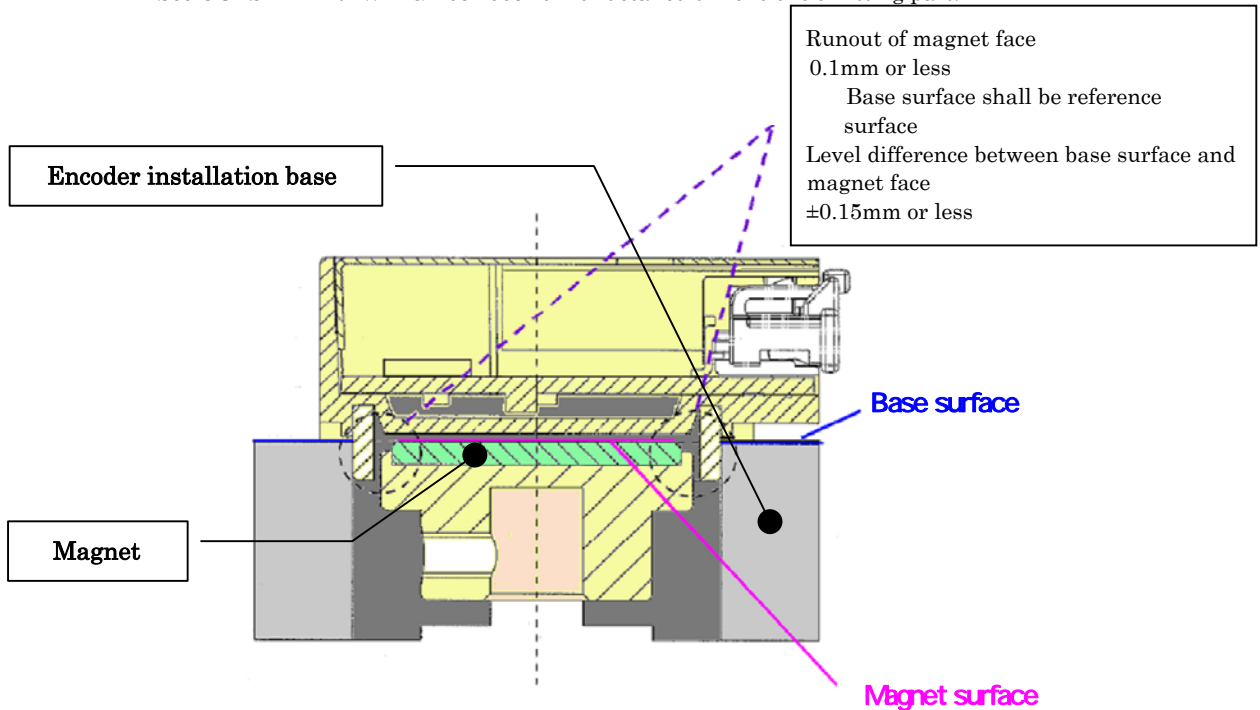

Fig. 3 Installation configuration

**3-5-2 Connector pin assignment**

A/Bch output

Pin No.	Terminal name	I/O	Content
1	VCC	-	Power voltage
2	GND	-	GND
3	NC	IN	No Connection
4	OUT 0	OUT	Zch or OUT terminal 0
5	OUT 1	OUT	Zch or OUT terminal 0
6	B	OUT	Bch
7	B	OUT	Bch
8	A	OUT	Ach
9	A	OUT	Ach

Serial communication output

Pin No.	Terminal name	I/O	Content
1	VCC	-	Power voltage
2	GND	-	GND
3	REQ	IN	Request signal
4	SPI_SDO	OUT	Communication data
5	SPI_SDO	OUT	Communication data
6	SPI_CLK	OUT	Communication clock
7	SPI_CLK	OUT	Communication clock
8	NC	OUT	No Connection
9	NC	OUT	No Connection

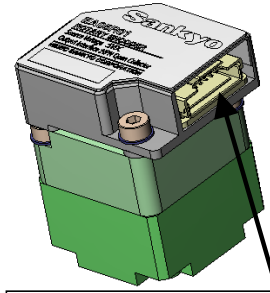

Pin No. 1, 2, 3 ... 9  
(From left as viewed from front of connector)

**Fig. 4 Pin number location**

Connector model No.  
Encoder connector model No.  
501568-0907 manufactured by Molex  
Corresponding connector model No.  
Housing  
501330-0900  
manufactured by Molex  
Contact  
501334-0000  
manufactured by Molex  
Use cable of not longer than 3 m.

**3-5-3 Input/output circuit**

Output circuit

RS422A line driver output (AM26C31 or equivalent) is adopted.

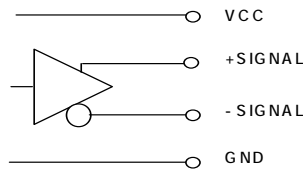

Input circuit

SN74LVC or equivalent is adopted.

Input voltage range	
High level	3.5V MIN
Low level	0.8V MAX

**3-5-4 Error handling**

Error handling is different respectively in A/Bch output mode and in serial communication output mode.

A/Bch output

Error factor

- a) Abnormality in MR (sensor) signal
- b) Excessive rotating speed (when electrical response frequency is exceeded)

How to return

After eliminating an error factor, turn on the power again.

How to output

RS422A line driver to be Hi impedance

Caution) Error factor can not distinguish

Serial communication output

Error factor

Abnormality in MR (sensor) signal

How to return

After eliminating an error factor, turn on the power again.

How to output

Set ERROR bit in communication data format to "1."

	OUT:1	OUT:2	OUT:3
Normal	-	-	-
Abnormal	"0"	"0"	"0"

**3-5-5 A/Bch specifications**

Phase relationship between rotating direction and A/Bch  
 In CW rotation.....Ach advance (Settable to Bch advance)  
 Note) CW rotation: As viewed from encoder ring side

Sampling and delay  
 Sampling is performed every 64 μ sec (15.6 kHz).  
 Delay time until pulses at the sampling position are ended to be discharged is 64 to 128 μ sec.

Incremental output, absolute output  
 This encoder requires 50 msec for startup processing time of a microcomputer.

Function/Specifications  
 As absolute outputs, absolute angle after microcomputer startup from power voltage turn-on is output for a maximum 10 msec (@ motor stationary state).  
 Absolute angle in power voltage turn-on can be detected by counting the output.  
 Incremental output is made when absolute output at power voltage turn-on is ended.

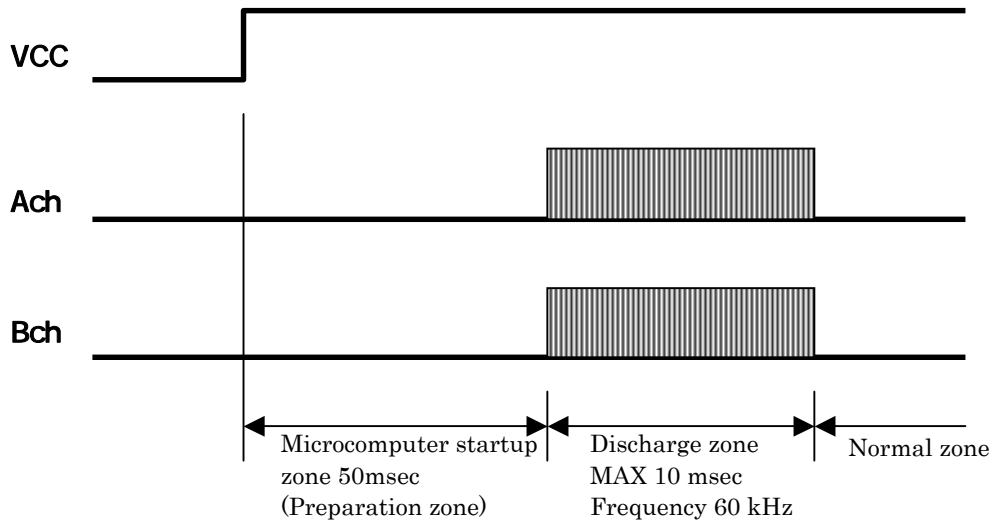

**Fig. 5 Absolute output in A/Bch mode**

Caution  
 When the motor was rotating at power voltage turn-on, the discharge time (absolute output) takes 10 msec or longer.

OUT terminal

Outline

When A/Bch mode is selected, OUT terminal of 4CH can be output.

User can set the OUT terminal to switch the output signal at any timing.

Example of function assignment

Output position (angle) of 1 to 4 pulses can be arbitrarily set.

(However, it is output at same interval angle.) (See output image shown below.)

Pulse output times [pulse/rev]	Adaptation example	Remarks	Output image
1	• Zch • U, V, Wch	One output at 360°	
2	• U, V, Wch	Output at every 180°	
3		Output at every 120°	
4		Output at every 90°	

Zch

Asynchronous with A/Bch

Positive logic (settable to negative logic)

Minimum pulse width: 64 μ sec

Origin position (One location per one rotation of motor)

Positive logic ..... Z phase=High, A phase=Low, B phase=Low

Negative logic (settable) ..... Z phase=Low, A phase=Low, B phase=Low

Origin position effective A/Bch maximum frequency is 3.5 kHz.

Supplemental description

If motor rotating speed exceeds A/Bch maximum frequency, more than one origin position is output.

When using the Zch for origin return, pay attention to the motor rotating speed.

How to obtain the Zch allowable rotating speed

Zch allowable rotating speed is specified from resolution [division/rev]

(after multiplying by four) and 3.5 kHz.

$$\text{Zch allowable rotating speed [rev/min]} = \frac{3500}{\text{resolution}} \times 60 \times 4$$

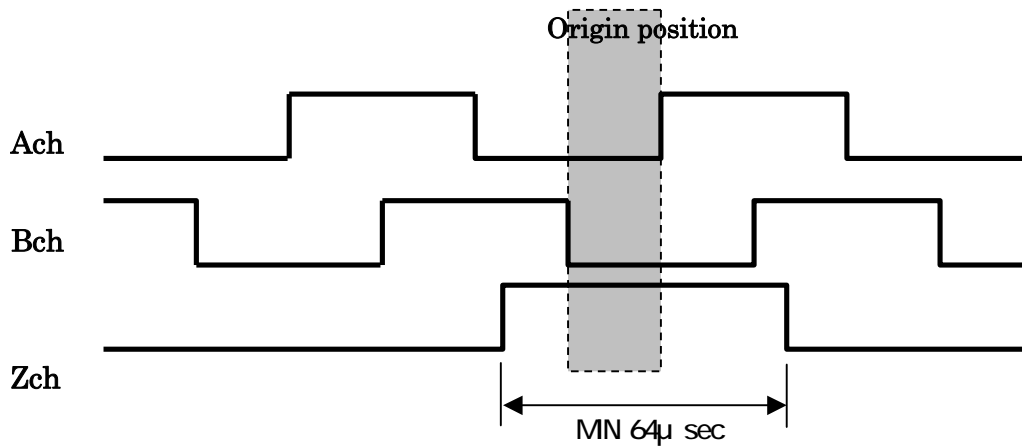
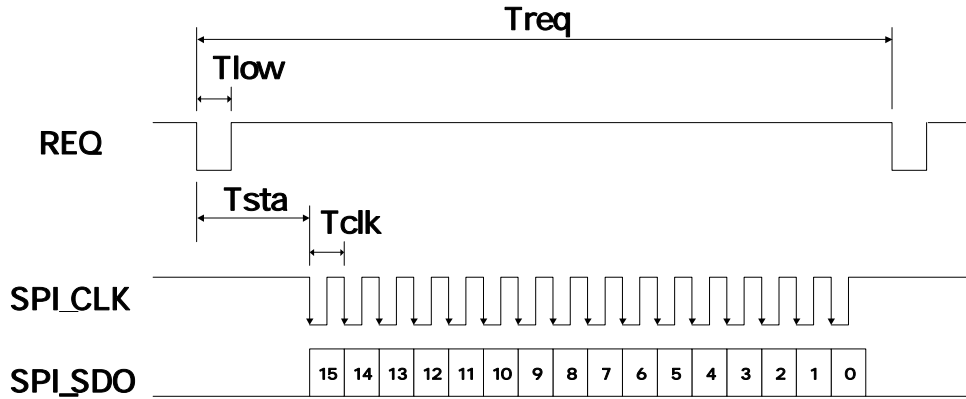

Fig. 6 Relationship between A/Bch and Zch

**3-5-6 Serial communication specifications**

**Communication specifications**

Name	Content
Control scheme	ONDEMAND scheme (Request input / angle output)
Communication scheme	Synchronous serial communication (SPI communication)
Clock	2MH
Data	16bit
Transmission data direction	MSB first (settable to LSB)



Symbol	Minimum value	Average value	Maximum value	Unit
Treq	64		Note 1	μsec
Tlow	0.5		30	μsec
Tsta	40		45	μsec
Tclk		0.5		μsec

Note 1 Relationship between request frequency (T req) [sec] and rotating speed [rpm]  
 Rotating speed < 30 / request frequency  
 If the above equation is not established, absolute angle will be deviated by 180 degrees.

**Flow of communication**

When REQ reaches the falling edge, the encoder starts angle detection.

Set REQ to high level within the time specified by Tlow.

Communication output starts after the time specified by Tsta.

Data (SPI\_SDO) is output from MSB (or LSB) at every 2 MHz (0.5 μ sec) in synchronization with clock (SPI\_CLK).

Transmission is output in synchronization with falling edge of the clock (SPI\_CLK).

Customer should receive data (SPI SDO) at rising of the clock (SPI CLK).

After communication is ended, the clock (SPI\_CLK) is fixed to high level.

**Operation when turning on power**

Input the request after 50 msec or longer have passed since turning on power.

**Output data format**

Its format can be selected from the following three types of formats (i) to (iii). (Parameter setting)

( ) Data length of absolute angle: 13 bit

15 (MSB)	14	13	12	11	10	9	8
R1	R2	ERROR	A12	A11	A10	A9	A8
7	6	5	4	3	2	1	0 (LSB)
A7	A6	A5	A4	A3	A2	A1	A0

Name	bit	Content
A0-A12	0-12	Absolute angle data per one rotation (MAX: 13 bit)
		In CW rotation: UP count (Settable to DOWN count)
ERROR	13	Error data
		Normal "0"
		Abnormal "1"
R2	14	Reserve
R1	15	Fixed to "1"

( ) Data length of absolute angle: 14 bit

15 (MSB)	14	13	12	11	10	9	8
R1	ERROR	A13	A12	A11	A10	A9	A8
7	6	5	4	3	2	1	0 (LSB)
A7	A6	A5	A4	A3	A2	A1	A0

Name	bit	Content
A0-A13	0-13	Absolute angle data per one rotation (MAX: 14 bit)
		In CW rotation: UP count (Settable to DOWN count)
ERROR	14	Error data
		Normal "0"
		Abnormal "1"
R1	15	Fixed to "1"

( ) Data length of absolute value angle: 15 bit

15 (MSB)	14	13	12	11	10	9	8
ERROR	A14	A13	A12	A11	A10	A9	A8
7	6	5	4	3	2	1	0 (LSB)
A7	A6	A5	A4	A3	A2	A1	A0

Name	bit	Content
A0-A13	0-14	Absolute angle data per one rotation (MAX: 14 bit)
		In CW rotation: UP count (Settable to DOWN count)
ERROR	15	Error data
		Normal "0"
		Abnormal "1"



400 499	
resolution	Pulse number of A/B phase
400	[ 100 ]
402	[ ]
404	[ 101 ]
406	[ ]
408	[ 102 ]
410	[ ]
412	[ 103 ]
414	[ ]
416	[ 104 ]
418	[ ]
420	[ 105 ]
422	[ ]
424	[ 106 ]
426	[ ]
428	[ 107 ]
430	[ ]
432	[ 108 ]
434	[ ]
436	[ 109 ]
438	[ ]
440	[ 110 ]
442	[ ]
444	[ 111 ]
446	[ ]
448	[ 112 ]
450	[ ]
452	[ 113 ]
454	[ ]
456	[ 114 ]
458	[ ]
460	[ 115 ]
462	[ ]
464	[ 116 ]
466	[ ]
468	[ 117 ]
470	[ ]
472	[ 118 ]
474	[ ]
476	[ 119 ]
478	[ ]
480	[ 120 ]
482	[ ]
484	[ 121 ]
486	[ ]
488	[ 122 ]
490	[ ]
492	[ 123 ]
494	[ ]
496	[ 124 ]
498	[ ]
	[ ]
	[ ]
	[ ]
	[ ]

500 600	
resolution	Pulse number of A/B phase
500	[ 125 ]
502	[ ]
504	[ 126 ]
506	[ ]
508	[ 127 ]
510	[ ]
512	[ 128 ]
516	[ 129 ]
520	[ 130 ]
524	[ 131 ]
528	[ 132 ]
532	[ 133 ]
536	[ 134 ]
540	[ 135 ]
544	[ 136 ]
548	[ 137 ]
552	[ 138 ]
556	[ 139 ]
560	[ 140 ]
564	[ 141 ]
568	[ 142 ]
572	[ 143 ]
576	[ 144 ]
580	[ 145 ]
584	[ 146 ]
588	[ 147 ]
592	[ 148 ]
596	[ 149 ]
600	[ 150 ]
604	[ 151 ]
608	[ 152 ]
612	[ 153 ]
616	[ 154 ]
620	[ 155 ]
624	[ 156 ]
628	[ 157 ]
632	[ 158 ]
636	[ 159 ]
640	[ 160 ]
644	[ 161 ]
648	[ 162 ]
652	[ 163 ]
656	[ 164 ]
660	[ 165 ]
664	[ 166 ]
668	[ 167 ]
672	[ 168 ]
676	[ 169 ]
680	[ 170 ]
684	[ 171 ]
688	[ 172 ]
692	[ 173 ]
696	[ 174 ]
	[ ]
	[ ]
	[ ]
	[ ]

700-800	
resolution	Pulse number of A/B phase
700	[ 175 ]
704	[ 176 ]
708	[ 177 ]
712	[ 178 ]
716	[ 179 ]
720	[ 180 ]
724	[ 181 ]
728	[ 182 ]
732	[ 183 ]
736	[ 184 ]
740	[ 185 ]
744	[ 186 ]
748	[ 187 ]
752	[ 188 ]
756	[ 189 ]
760	[ 190 ]
764	[ 191 ]
768	[ 192 ]
772	[ 193 ]
776	[ 194 ]
780	[ 195 ]
784	[ 196 ]
788	[ 197 ]
792	[ 198 ]
796	[ 199 ]
800	[ 200 ]
804	[ 201 ]
808	[ 202 ]
812	[ 203 ]
816	[ 204 ]
820	[ 205 ]
824	[ 206 ]
828	[ 207 ]
832	[ 208 ]
836	[ 209 ]
840	[ 210 ]
844	[ 211 ]
848	[ 212 ]
852	[ 213 ]
856	[ 214 ]
860	[ 215 ]
864	[ 216 ]
868	[ 217 ]
872	[ 218 ]
876	[ 219 ]
880	[ 220 ]
884	[ 221 ]
888	[ 222 ]
892	[ 223 ]
896	[ 224 ]
	[ ]
	[ ]
	[ ]
	[ ]

900-1100	
resolution	Pulse number of A/B phase
900	[ 225 ]
904	[ 226 ]
908	[ 227 ]
912	[ 228 ]
916	[ 229 ]
920	[ 230 ]
924	[ 231 ]
928	[ 232 ]
932	[ 233 ]
936	[ 234 ]
940	[ 235 ]
944	[ 236 ]
948	[ 237 ]
952	[ 238 ]
956	[ 239 ]
960	[ 240 ]
964	[ 241 ]
968	[ 242 ]
972	[ 243 ]
976	[ 244 ]
980	[ 245 ]
984	[ 246 ]
988	[ 247 ]
992	[ 248 ]
996	[ 249 ]
1000	[ 250 ]
1004	[ 251 ]
1008	[ 252 ]
1012	[ 253 ]
1016	[ 254 ]
1020	[ 255 ]
1024	[ 256 ]
1032	[ 258 ]
1040	[ 260 ]
1048	[ 262 ]
1056	[ 264 ]
1064	[ 266 ]
1072	[ 268 ]
1080	[ 270 ]
1088	[ 272 ]
1096	[ 274 ]
1104	[ 276 ]
1112	[ 278 ]
1120	[ 280 ]
1128	[ 282 ]
1136	[ 284 ]
1144	[ 286 ]
1152	[ 288 ]
1160	[ 290 ]
1168	[ 292 ]
1176	[ 294 ]
1184	[ 296 ]
1192	[ 298 ]
	[ ]
	[ ]
	[ ]
	[ ]

1200-1500	
Resolution	Pulse number of A/B phase
1200	300
1208	302
1216	304
1224	306
1232	308
1240	310
1248	312
1256	314
1264	316
1272	318
1280	320
1288	322
1296	324
1304	326
1312	328
1320	330
1328	332
1336	334
1344	336
1352	338
1360	340
1368	342
1376	344
1384	346
1392	348
1400	350
1408	352
1416	354
1424	356
1432	358
1440	360
1448	362
1456	364
1464	366
1472	368
1480	370
1488	372
1496	374
1504	376
1512	378
1520	380
1528	382
1536	384
1544	386
1552	388
1560	390
1568	392
1576	394
1584	396
1592	398

1600-1900	
Resolution	Pulse number of A/B phase
1600	400
1608	402
1616	404
1624	406
1632	408
1640	410
1648	412
1656	414
1664	416
1672	418
1680	420
1688	422
1696	424
1704	426
1712	428
1720	430
1728	432
1736	434
1744	436
1752	438
1760	440
1768	442
1776	444
1784	446
1792	448
1800	450
1808	452
1816	454
1824	456
1832	458
1840	460
1848	462
1856	464
1864	466
1872	468
1880	470
1888	472
1896	474
1904	476
1912	478
1920	480
1928	482
1936	484
1944	486
1952	488
1960	490
1968	492
1976	494
1984	496
1992	498

2000-2900			
Resolution	Pulse number of A/B phase	Resolution	Pulse number of A/B phase
2000	500	2800	700
2008	502	2816	704
2016	504	2832	708
2024	506	2848	712
2032	508	2864	716
2040	510	2880	720
2048	512	2896	724
2064	516	2912	728
2080	520	2928	732
2096	524	2944	736
2112	528	2960	740
2128	532	2976	744
2144	536	2992	748
2160	540		
2176	544		
2192	548		
2208	552		
2224	556		
2240	560		
2256	564		
2272	568		
2288	572		
2304	576		
2320	580		
2336	584		
2352	588		
2368	592		
2384	596		
2400	600		
2416	604		
2432	608		
2448	612		
2464	616		
2480	620		
2496	624		
2512	628		
2528	632		
2544	636		
2560	640		
2576	644		
2592	648		
2608	652		
2624	656		
2640	660		
2656	664		
2672	668		
2688	672		
2704	676		
2720	680		
2736	684		
2752	688		
2768	692		
2784	696		





#### 4 Reliability test

Test item	Test condition	Standard
Vibration	10~150Hz (1s for one way) Apply 2G in X, Y, Z directions for 2H. Apply 3G in X, Y, Z directions for 30s.	There shall be no abnormality in output value.
Impact	Acceleration:10G 11 msec: X, Y, Z	There shall be no abnormality in output value.

**5 Cautions in handling**

This product has not been designed in consideration of use under the following special environments.  
 For use under the following special environments, sufficiently check the performance and reliability in your company.

- Use in liquids such as water, oil, chemical and organic solvent
- Use in liquids such as water, oil, chemical and organic solvent
- Use in corrosive gas atmospheres such as salt air, Cl<sub>2</sub>, H<sub>2</sub>S, NH<sub>3</sub>, SO<sub>2</sub>, Nox
- Use under an environment affected by static electricity, surge and electromagnetic waves

- B)** This product may be broken by surge and excessive voltage.  
Function/Specifications
- C)** Do not contact the sealing resin and coating with a hard object.
- D)** Note that we will not guarantee any defect due to use beyond description in this delivery specification, and model and application development without consulting us.
- E)** If it is predicted that loss of human life or other serious damage occurs due to failure of this product, take appropriate measures for fail-safe design under the following considerations to ensure safety.
  - To provide protective circuit and protective device for safety as a system.
  - To provide redundant circuit for safety as a system so as to avoid unsafe operation in single failure.
- F)** If the Vcc and GND terminals are inversely connected and voltage is applied, excessive current may flow, resulting in heat generat Connector pin assignment
- G)** About handling of magnet
  - Do not attach the magnets to each other.
  - Apply screw locking agent to the magnet holder mounting screws.
  - Do not paint the magnet surface.
  - If the mag A/B ch specifications these items may become unusable.
  - If the magnet is brought close to precision devices such as a personal computer, cellular phone and watch, these items may malfunction.
  - If the magnet is brought close to electronic medical equipment such as a heart pacer, normal operation may be impaired.
  - If the magnet is used outside the usable temperature range, magnetic force may be reduced.
  - The magnetic appearance standard is shown below.

Item	Item schematic diagram (Sample)	Acceptable criteria	Remarks
Chip		1. Size of chip shall be as follows. L 2.0, W 1.0, D (depth) 0.5 L: Direction along the side W, D: Two directions perpendicular to the side (L), W is in the long direction and D is in the short direction (directions of W and D are not related to the direction of the magnet.) 2. Chips of the above size shall be up to three locations/magnet. 3. 0.5 (L) × 0.5 (W) × 0.5 (D) or less is not regarded as a chip.	
Crack		1. Length of crack shall be as follows (a). L 2.0 2. Crack with the above length shall be up to one line/magnet. 3. However, crack of closed loop and opened crack are not allowed.	
Discoloration, stain		1. Discoloration and stain which are not removed with taping and alcohol are allowed.	Taping NICHIBAN Crepe tape #331 or equivalent

### 6 OUTSIDE DRAWING

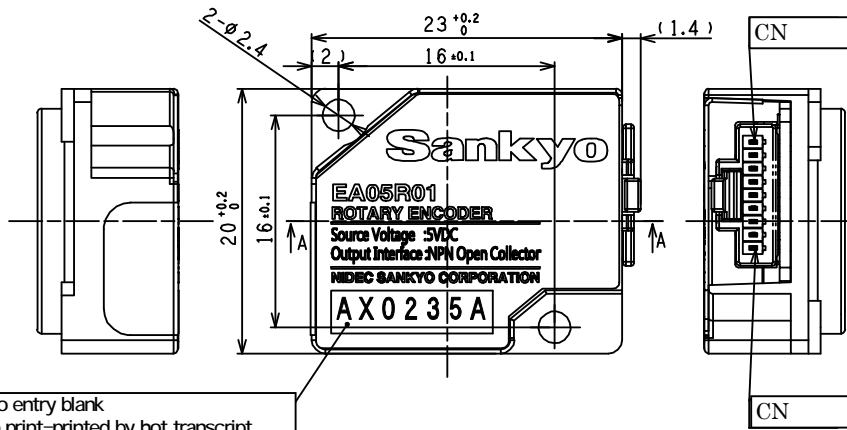

Serial No entry blank  
 How to print=printed by hot transcript  
 Serial No note tool  
 Example:2008oct NO.235 Rev.A  
 Write=AX0235A  
 Symbol Rule  
 Year Month Serial No Revision No  
 Rule detail  
 Year  
 A=2008,B=2007,,,E=2012  
 Month  
 1=Jan, 2=Feb,,,, 9=Sep  
 X=Oct, Y=Nov, Z=Des  
 Serial No  
 0000-9999  
 Revision Status symbol  
 A=Rev A . B=Rev B

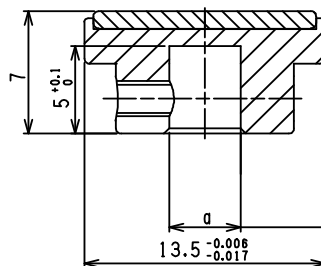
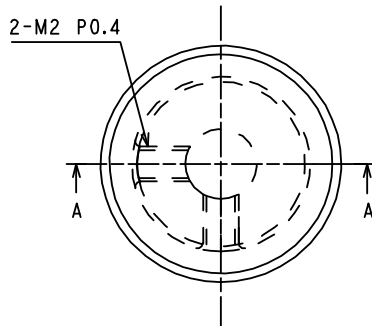
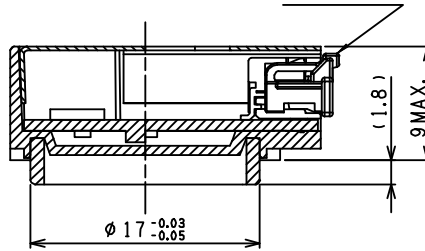

Model	φa
PSET011	φ5 +0.02/0
PSET012	φ4 +0.02/0