

Programmable Magnetic Encoder EA Series

EA Series consists of remarkably small rotary encoders which adopt a one pole magnetic type in order to respond downsizing demands from the market.

Difficult to downsize in conventional types EA Series

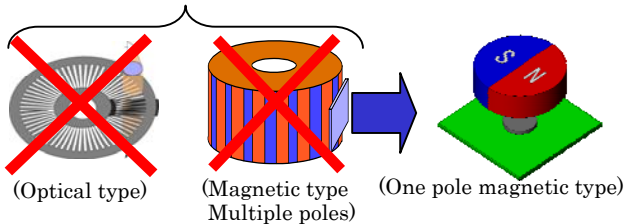

Simple structure is indispensable to downsizing.

【Features】

- **Absolute Encoder**
Single turn absolute encoder
- **Small & Thin Type**
Optimum size for □20mm stepping motor
- **Strong for Bad Environments**
Adaptable for heavy dust and oil mist environments
- **Easy Installation**
Installation completed in little minute
- **Parameters Allow for Variable Settings (Patent Pending)**
Parameters can be set by Windows based software and TTL level UART communication.
<Example of parameter settings>
 - Switching of A/B phase /serial communication
 - Origin adjustment of absolute
 - Change of resolution
 - Setting of output
 Example) Setting to Z/U/V/W phase signal
- **Two Types of Interfaces Available**
Open collector and line driver
Two types of interfaces available

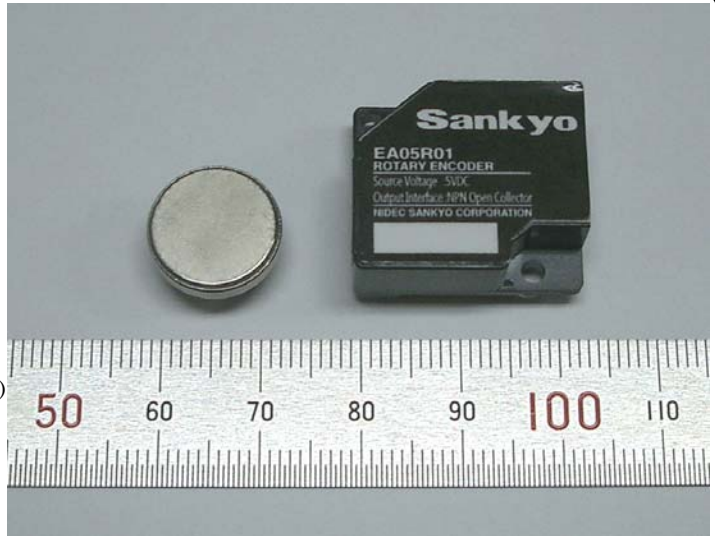

【Operating principle】

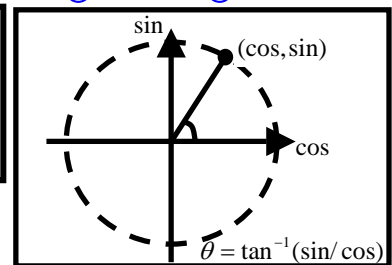
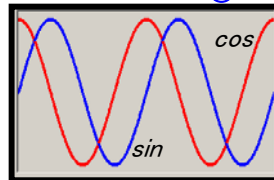
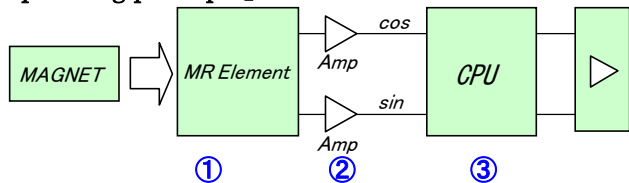

<Description of operating principle>

- (1) Change of the magnetic flux is detected by MR element.
- (2) Sin and cos signals (Fig.1) which are output by MR element are amplified and captured in a CPU by AD converter.
- (3) Angle is calculated through ATAN calculation (Fig. 2) by a CPU.

【Angle accuracy】

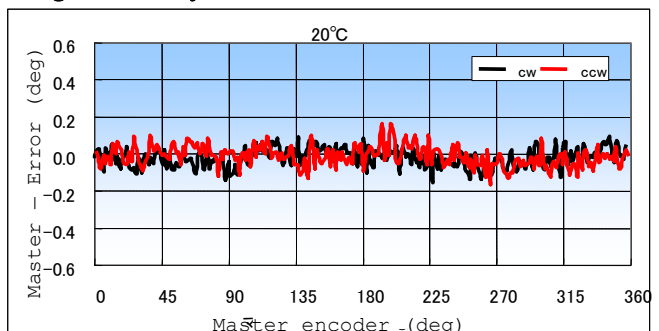

◆How to Install

1. Assembling magnet

Assemble a magnet to a shaft, insert a height setting jig and fix the magnet with screws.

2. Placing and assembling spacer

Place a spacer, insert a centering jig and tighten the screws.

3. Placing and assembling spacer

Place an encoder on the spacer and tighten it with bolts.

complete

Easy installation!

Installation completed little minute

* Spacer should be prepared by customer depending on shaft protruding dimensions.

◆Input/Output Interface

【Connector Pin Location】

Pin No.	< Open collector >			Serial communication			< Line driver >			Serial communication		
	Terminal name	I/O	Content	Terminal name	I/O	Content	Terminal name	I/O	Content	Terminal name	I/O	Content
1	VCC	-	Voltage	VCC	-	Voltage	VCC	-	Voltage	VCC	-	Voltage
2	GND	-	GND	GND	-	GND	GND	-	GND	GND	-	GND
3	NC	IN	No Connection	REQ	IN	Request signal	NC	IN	No Connection	REQ	IN	Request signal
4	A	OUT	Ach	NC	OUT	No Connection	-OUT:0	OUT	-Zch or -OUTterminal0	-SPI_SDO	OUT	-Communication data
5	OUT:0	OUT	Zch or OUTterminal0	SPI_SDO	OUT	Communication data	+OUT:0	OUT	+Zch or +OUTterminal0	+SPI_SDO	OUT	+Communication data
6	OUT:1	OUT	Uch or OUTterminal1	SPI_CLK	OUT	Communication clock	+B	OUT	+Bch	+SPI_CLK	OUT	+Communication clock
7	B	OUT	B phase	NC	OUT	No Connection	-B	OUT	-Bch	-SPI_CLK	OUT	-Communication clock
8	OUT:2	OUT	Vch or OUTterminal2	OUT:2	OUT	Vch or OUTterminal2	-A	OUT	-Ach	NC	OUT	No Connection
9	OUT:3	OUT	Wch or OUTterminal3 or error output	OUT:3	OUT	Wch or OUTterminal3	+A	OUT	+Ach	NC	OUT	No Connection

Encoder connector model No. : 501568-0907 manufactured by molex

Corresponding connector model No. : Housing 501330-0900 manufactured by molex

Contact 501334-0000 manufactured by molex

※USB cable of not longer than 3m

【Interface Circuit】

●Output circuit

NPN open collector output (SN74LV07 or equivalent) is adopted.

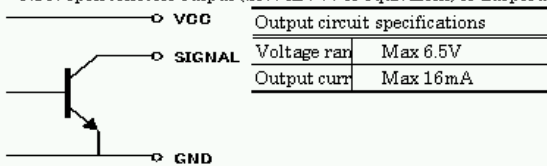

* Because the output frequency is 2 MHz in serial communication, set the recommended pull-up resistance value of SPI_SDO and SPI_CLK to approximately 390Ω.

●Input circuit

SN74LVC or equivalent is adopted.

Input voltage range	
High level	3.5V MIN
Low level	0.8V MAX

●Output circuit

RS422A Line driver (AM26C31 or equivalent) is adopted

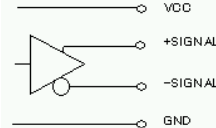

●Input circuit

SN74LVC or equivalent is adopted

Input voltage range	
High level	3.5V MIN
Low level	0.8V MAX

【Serial Communication Specifications】

Name	Content
Control method	ONDEMAND scheme (request input/angle output)
Communication scheme	Synchronous serial communication (SPI communication)
Clock	2MHz
Data	16bit
Transmission data direction	MSB first (settable to LSB)

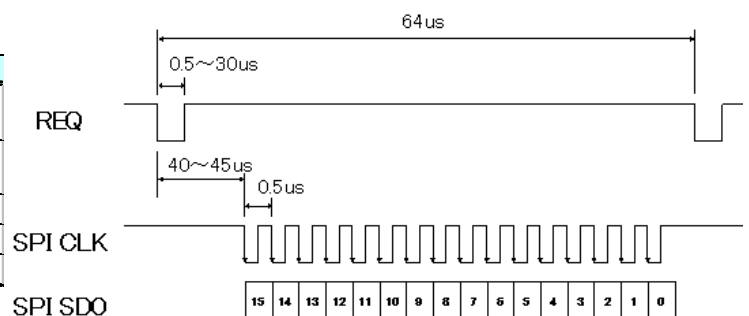

◆ Parameter Change Function

Parameters in the encoder can be changed by Windows based software.

1. Output mode

Two types of output modes of A/Bch and serial communication (SPI communication method) can be selected.

2. Resolution [Division/Rev]

Any division number up to 8192 [div/rev] for A/Bch and up to 32768 [div/rev] for serial communication can be set.

3. Encoder count-up direction

Direction of encoder count-up and count-down to the rotating direction can be set.

4. Setting output phase

In addition to A/Bch, open collector type has four outputs and line driver type has one output. These outputs can be switched to HI level or LO level at any position in one rotation by parameter setting. ex) in the case of four outputs: U-ch, V-ch, W-ch and Z-ch outputs can be set.

5. Origin adjustment

Origin of absolute for one rotation can be changed with the encoder installed on the customer's mechanism part.

6. Write to memory

Memory area (64 Byte) open to a customer is prepared in the encoder. Customer's Specific information can be recorded in this area. ex) Serial number, motor specific information etc.

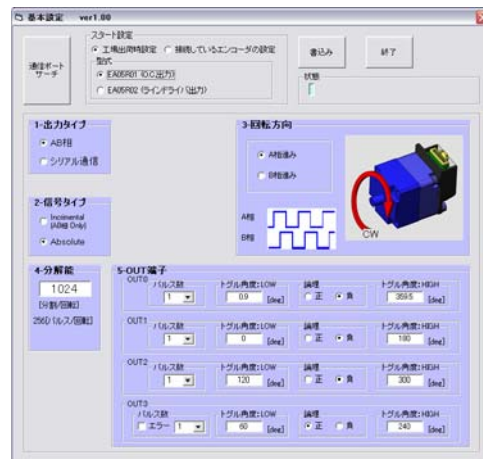

Parameter setting software sample (Note 1)

【How to connect】

REQ signal terminal and SPI_SDO signal terminal are used as UART (5V-TTL level) in parameter setting communication. Connect the Rx and Tx signals on the upper level side as shown in the following diagram.

Open Collector type

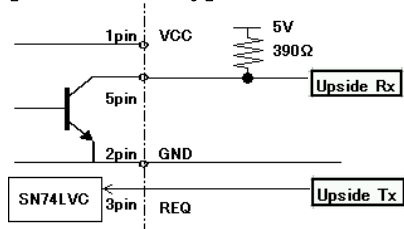

Line Driver type

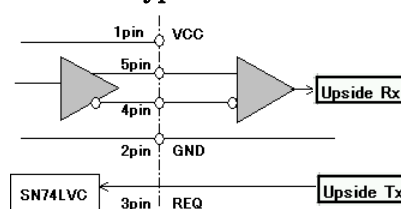

【Communication format】

Synchronization method	Start-stop synchronous communication
Control method	Command / Response method
Transmission method	Full-duplex communication method
Communication setting	9600 bps, data 8 bit, no parity, STOP bit: 1 Bit

【Factory shipping setting】

Parameter setting item	Setting content
Output mode	A/Bch
Resolution	1024 [division/rev] (256 [pulse/rev])
A/Bch direction	A-ch advance (in CW rotation)
OUT terminal setting	Z, U, V, W ch [1 pulse/rev]
A/Bch mode	Absolute
Error signal	Output in combination of U, V and Wch

(Note 1) Parameter setting software sample

For the communication method, its source is published as sample software. Read / write of the memory can be utilized online by mounting into a customer's control device. Sample software for each function such as (1) Encoder mode / parameter setting mode switching, (2) Basic function setting, (3) Edit of memory and (4) Origin adjustment can be downloaded from the following URL.

<http://www.nidec-sankyo.co.jp/pro/parts/01.htm>

◆ Standard Performance

type	EA05R01	EA05R03
Output interface	Open Collector	Line Driver type(RS422-Abase) (Output driver AM26C31corresponding)
Output	4 output (example : Z、U、V、Wch)	1 output (example : Zch)

Absolute maximum rating

Spec item	Content	
Voltage VCC	DC -0.3V ~ +5.5 V	
Input voltage Vin	0 ~ VCC V	
Operating ambient temp	-10°C ~ +85°C	
Operating ambient humidity	20 ~ 80%RH (No condensation)	
Storage temp	-10°C ~ +90°C	

Mechanical spec

Spec item	Content	
External disturbance magnetic field	Within ±2m	
Mass	Sensor part	6.0g or less
	Magnetic part	5.5g or less
Magnet inertia moment	0.85 g · cm ²	

Electical spec

Spec item	A/Bch	Serial communication
Recommended power supply	DC 5V ± 10%	
Consumption current	20mA or less	
Output method	A/Bch	Binary (Serial)
Maximum response frequency (Response pulse number)	60 KHz	—
Allowable maximum rotating speed (Electical)	Note 1	Note 2
Maximum resolution	8192 [division/rev] (2048 [pulse/rev])	32768 [division/rev]

Note1) Allowable maximum rotating speed in A/B phase mode Maximum rotation speed is specified from resolution [div/rev] (after multiplying by four) and maximum response frequency [Hz].

Note2) Allowable maximum rotating speed in serial communication mode Maximum rotation speed is specified from request frequency [sec].

$$\text{Maximum rotation speed [rev/min]} = \frac{\text{Maximum response frequency (60 [KHz])}}{\text{Resolution}} \times 60 \times 4$$

$$\text{Maximum rotation speed [rev/min]} = \frac{30}{\text{request frequency}}$$

◆ Outline Dimension

ENCODER OUTLINE

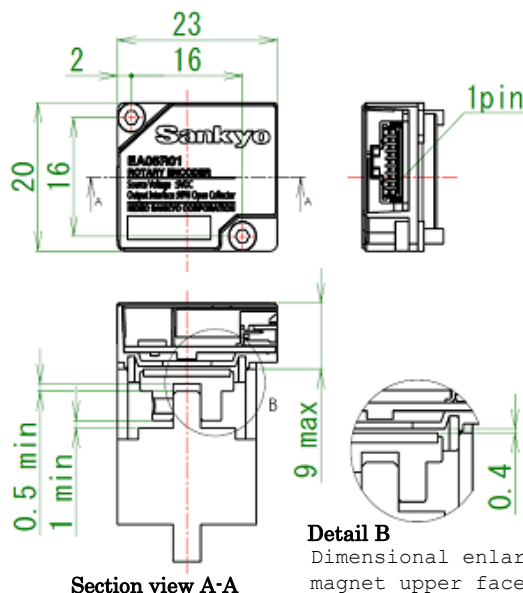

ROTOR_MAGNET OUTLINE

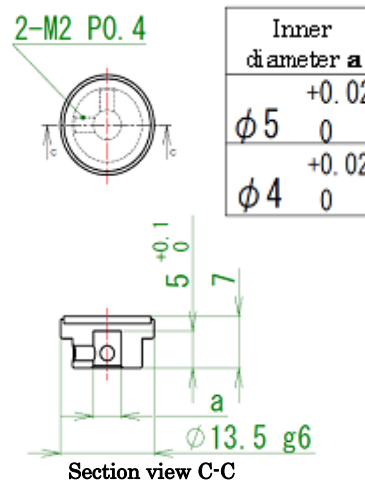

Note) The above contents may be subject to change without prior notice.

<SALES DEPARTMENT>

<DEVELOPMENT・PRODUCTION>

NIDEC SANKYO CORPORATION

- New market researching DEPT (Tokyo office) 1-20-13, Osaki, Shinagawa-ku, Tokyo 141-0032, Japan
TEL: (81) 3-5740-3006 FAX: (81) 3-6843-3123
- New market researching DEPT (Komagane facility) 14-888, Akaho, Komagane-shi, Nagano 399-4117, Japan
TEL: (81) 265-81-7004 FAX: (81) 265-82-5634